

INSTRUCTION SHEET

SH-WR SERIES

ZERO SPACE RACKSHELF

WEIGHT CAPACITY

250 Lb. Capacity



**MUST ONLY USE SCREWS
SUPPLIED WITH SHELF TO
ACHIEVE WEIGHT CAPACITY**

INSTALLATION

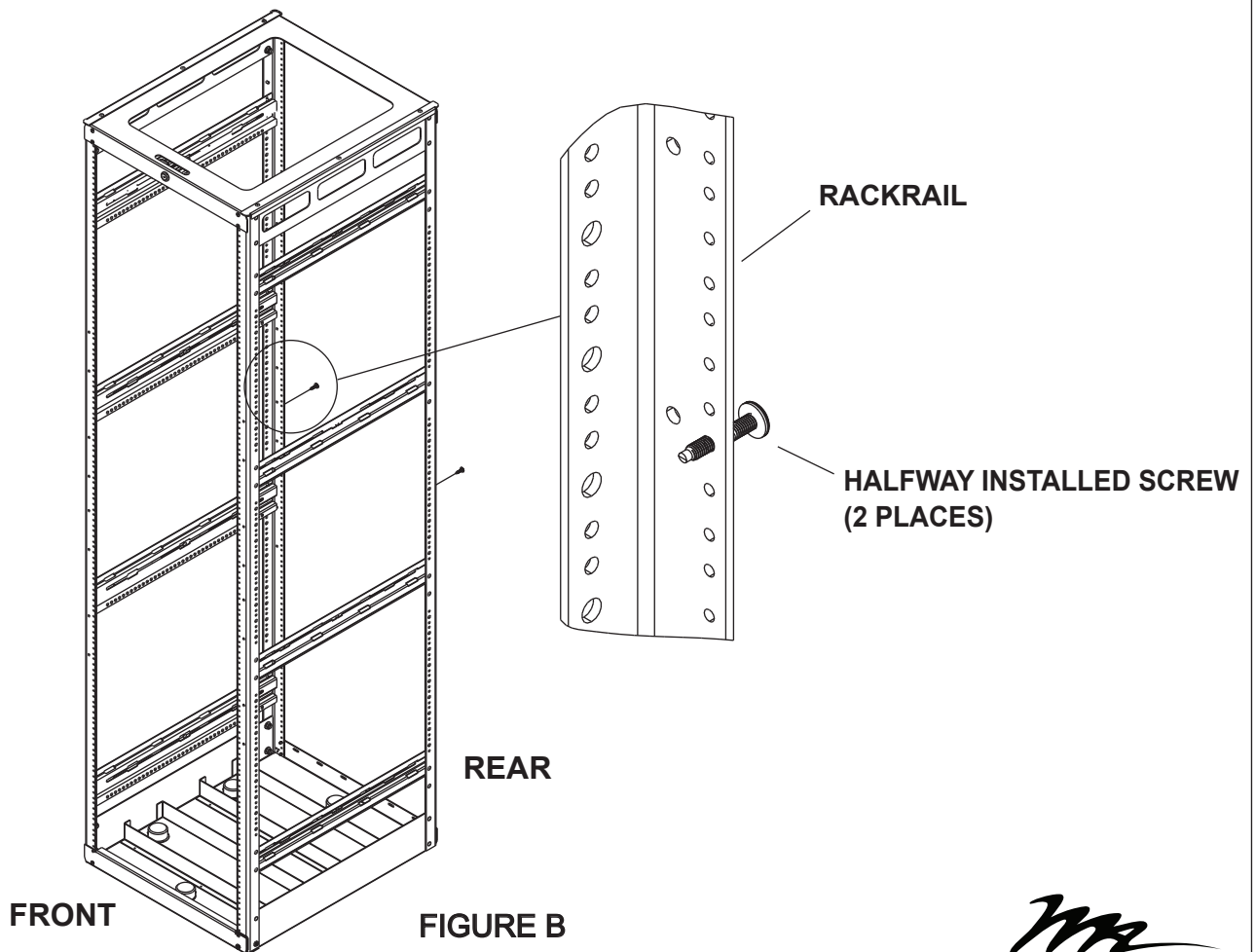
- 1) Determine the type of shelf mounting desired.
(FLANGE UP or FLANGE DOWN)
(See FIGURE A)

NOTE: Shelf micro-adjusts within all EIA system threaded mounting holes

- 2) Determine location of shelf and install provided
screws (2 places) halfway into rear rackrail. (See FIGURE B)

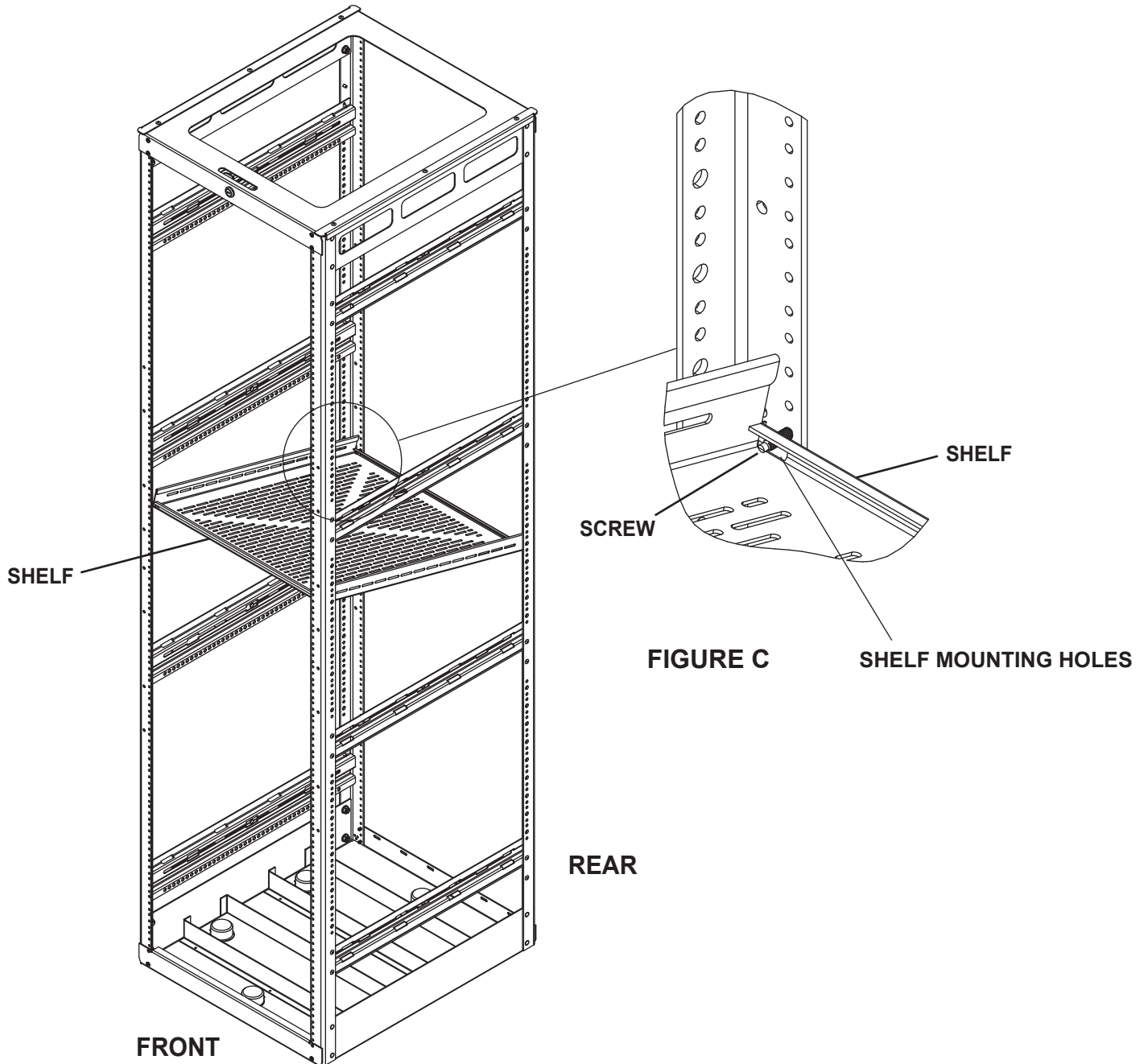


FIGURE A



ASSEMBLY (Continued)

- 3) Tilt shelf into position as shown, align installed screws into the shelf mounting holes.
(See FIGURE C)



ASSEMBLY (Continued)

- 4) Level shelf into position and install remaining screws (2 places) through rackrail into shelf holes. (See FIGURE D)
- 5) Tighten all shelf screws securely.

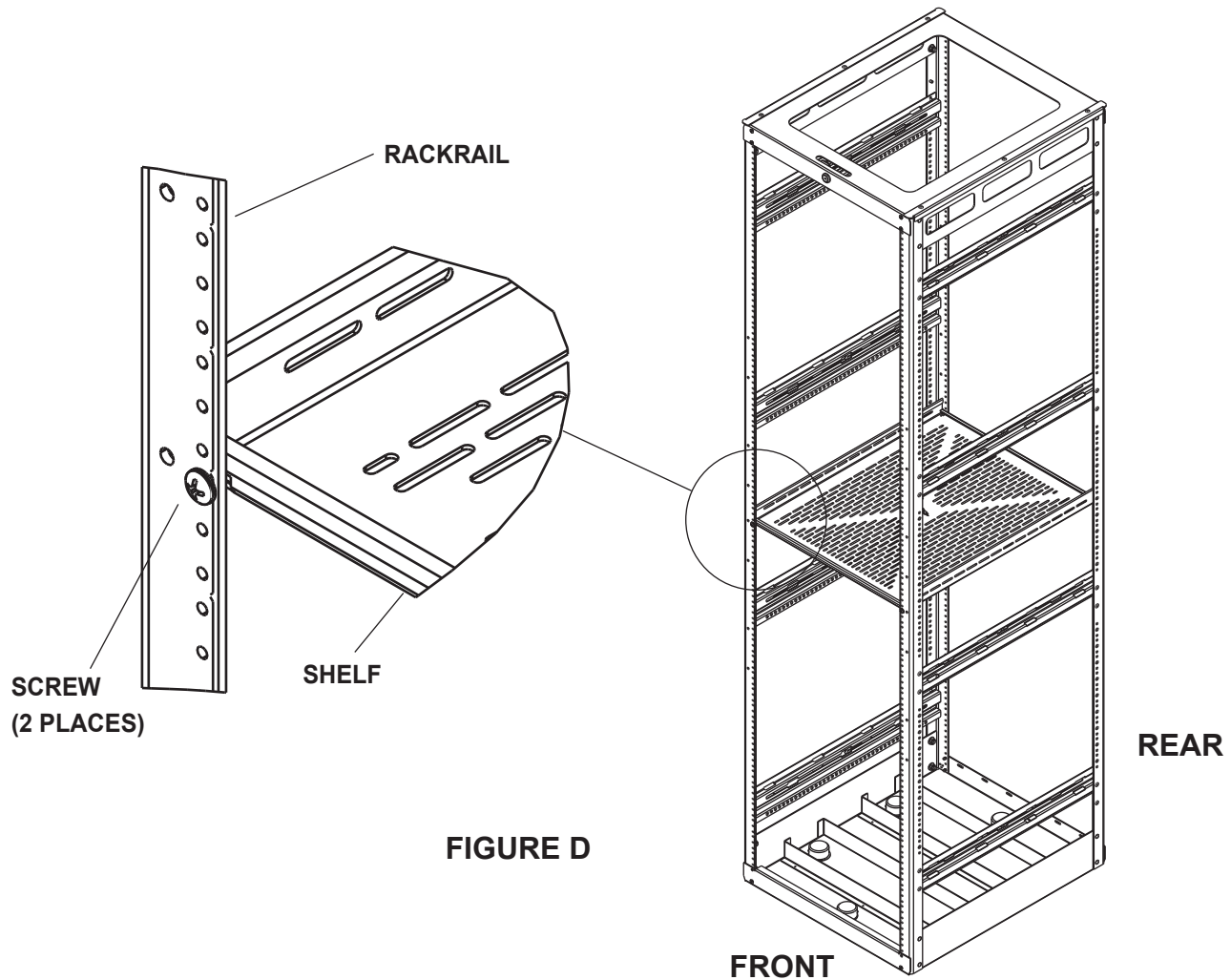


FIGURE D

WARRANTY

Middle Atlantic Products, Inc. (the "Company") warrants the SH-WR Series Zero Space Rackshelf to be free from defects in material or workmanship under normal use and conditions for the lifetime of the product.

The Company's entire liability to the purchaser, and the purchaser's (or any other party's) sole and exclusive remedy, under this warranty shall be limited, at the Company's option, to either (a) return of and refund of the price paid for, or (b) repair or replacement at the Company's factory of the products purchased, or any part or parts thereof, which the Company has determined to be defective after inspection thereof at the Company's factory.

This warranty does not cover damage due to acts of God, accident, misuse, abuse or negligence by parties other than the Company, or any modification or alteration of the products. In addition, this warranty does not cover damage due to improper handling, assembly, installation or maintenance.

THIS WARRANTY IS IN LIEU OF ALL OTHER WARRANTIES OF ANY KIND, EITHER EXPRESSED OR IMPLIED, INCLUDING, BUT NOT LIMITED TO, IMPLIED WARRANTIES OF MERCHANTABILITY AND FITNESS FOR A PARTICULAR PURPOSE.

TO THE MAXIMUM EXTENT PERMITTED BY APPLICABLE LAW, IN NO EVENT SHALL THE COMPANY BE LIABLE FOR ANY SPECIAL, INCIDENTAL, INDIRECT, OR CONSEQUENTIAL DAMAGES WHATSOEVER (INCLUDING, WITHOUT LIMITATION, DAMAGES FOR LOSS OF BUSINESS PROFITS, BUSINESS INTERRUPTION OR ANY OTHER PECUNIARY LOSS) ARISING OUT OF THE USE OF THE PRODUCTS PURCHASED, EVEN IF THE COMPANY HAS BEEN ADVISED OF THE POSSIBILITY OF SUCH DAMAGES. THE COMPANY'S LIABILITY TO THE PURCHASER (OR ANY OTHER PARTY) HEREUNDER, IF ANY, SHALL IN NO EVENT EXCEED THE PURCHASE PRICE OF THE PRODUCTS PAID TO THE COMPANY.

Corporate Headquarters

Corporate Voice 973-839-1011 - Fax 973-839-1976
International Voice +1 973-839-8821 - Fax +1 973-839-4982
middleatlantic.com - info@middleatlantic.com

Middle Atlantic Canada

Voice 613-836-2501 - Fax 613-836-2690
middleatlantic.ca - customerservicecanada@middleatlantic.ca

Factory Distribution

USA: NJ - CA - IL Canada: ON - BC

At Middle Atlantic Products we are always listening. Your comments are welcome.



30% Recycled Paper