

INSTRUCTION SHEET

UD 1

ONE RACKSPACE DRAWER

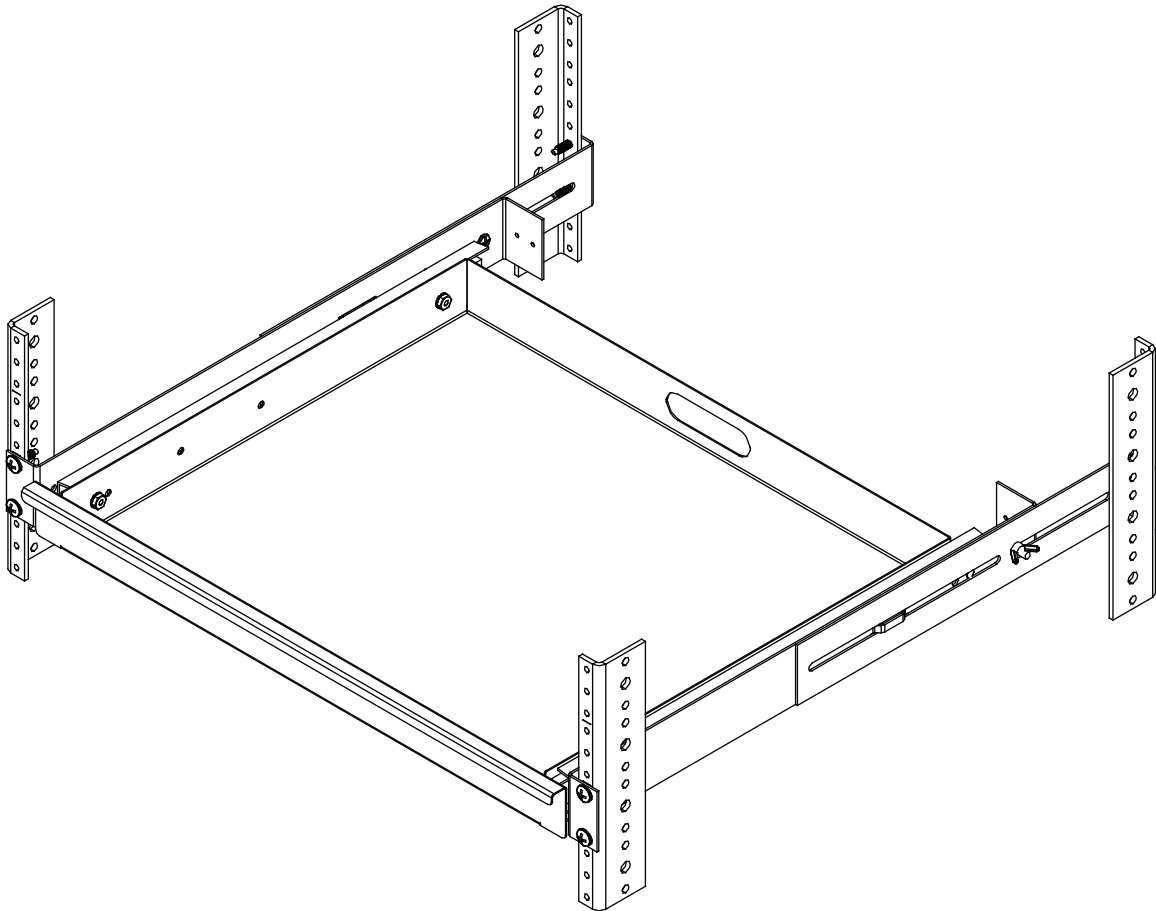

THANK YOU

Thank you for purchasing the UD1 one rackspace drawer. Please read these instructions thoroughly before installing/assembling this product.

PRODUCT FEATURES

- Reversible design allows the drawer to be flipped over for use as a slide-out shelf for the the following applications: writing surface, laptop and keyboard holder.
- Cable knockout at rear of drawer allows for efficient routing of cabling.



Middle Atlantic Products, Inc.

I-00333 Page 1 Rev -

SUPPLIED HARDWARE

 (2) 10-32 Wing nuts

 (4) 6-32 X .25 Self threading screws

 (4) #10 X .625 Pan head wood screws

 (2) 10-32 X .5 Pan head machine screws

 (2) Side mounting brackets (For wood installation)

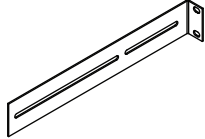
 (2) Rear mount brackets (For use with Rackrail)

NOTE: Drawer weight capacity is 50 pounds.

INSTALLATION WITH REAR MOUNTING BRACKETS (USE WITH REAR RAIL)

1) Position drawer in rack before attaching rear mounting brackets.

2) With drawer positioned in the rack, attach the supplied rear mounting brackets to each side as shown using the supplied hardware. **(FIGURE A)**

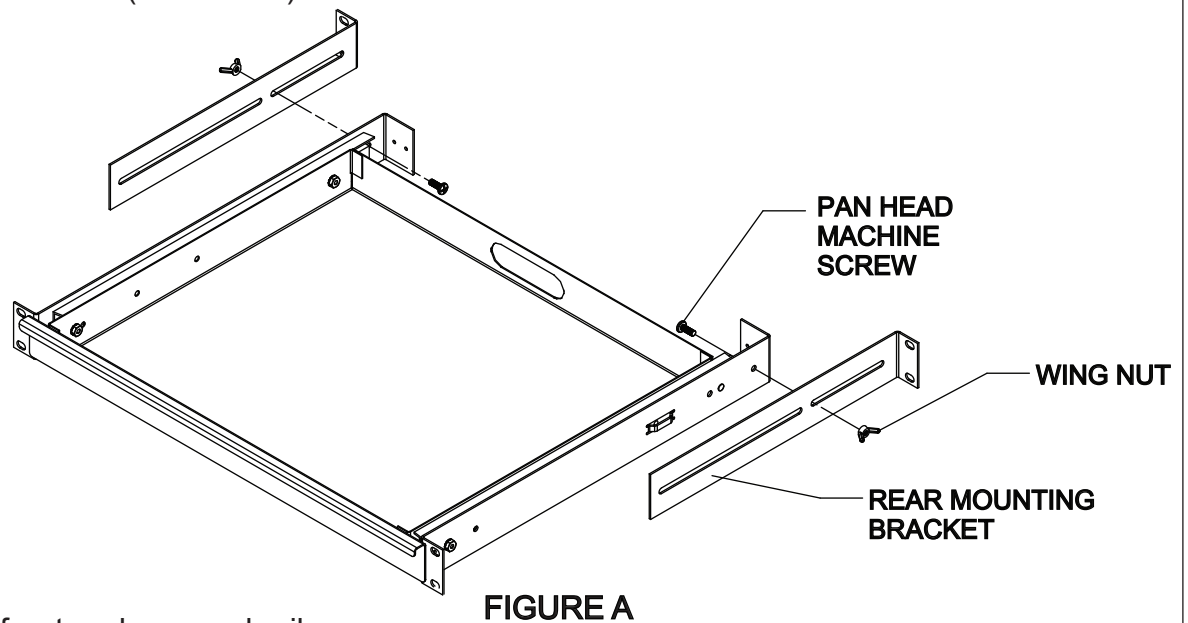

3) Install drawer to the front and rear rackrails as shown. **(FIGURE B)**

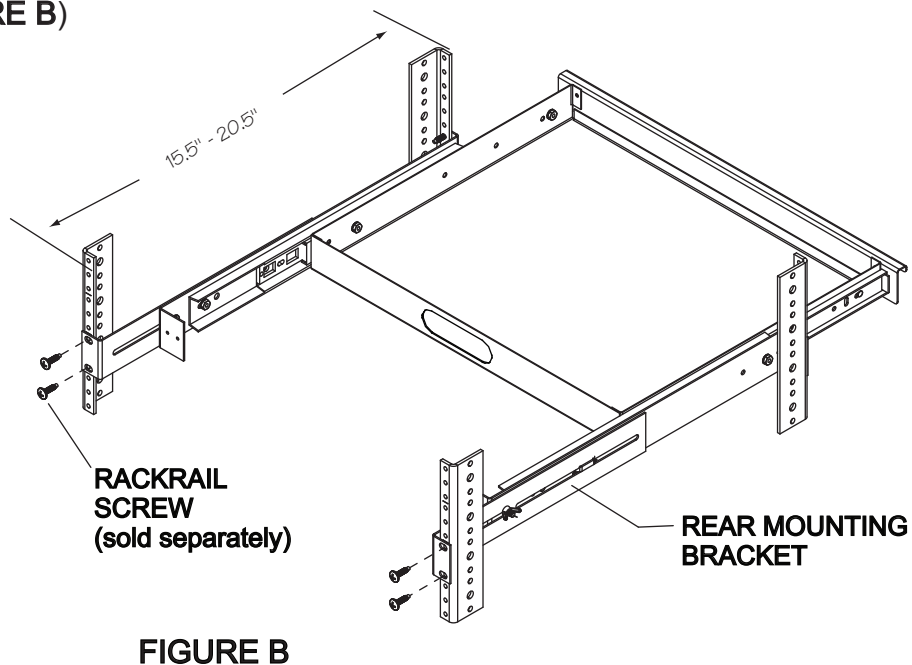

INSTALLATION WITH SIDE MOUNTING BRACKETS (USE WITH WOOD RACKS/CASES)

- 1) Attach the drawer to the front rackrail before attaching the side mounting brackets
- 2) Attach the side mounting brackets to the drawer and then attach to the sides of the rack as shown using the supplied hardware. (FIGURE C)

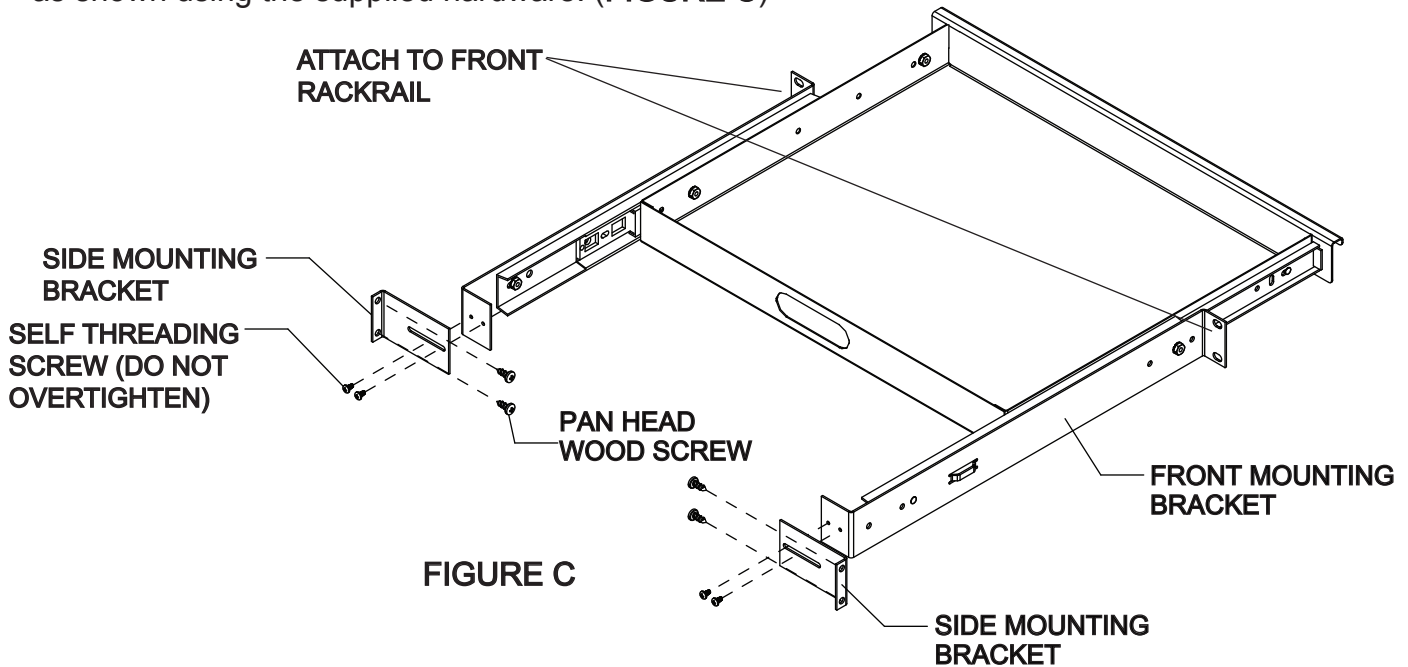

CONVERTING FROM DRAWER TO SHELF AFTER INSTALLATION

- 1) Open the drawer and simultaneously push the right side quick release latch down and the left side latch up, and slide the drawer out from the tracks. (FIGURE D)
- 2) Flip the drawer over and insert onto the tracks. Close the shelf to lock it on the tracks.

NOTE: The above steps are the same for converting from shelf to drawer.

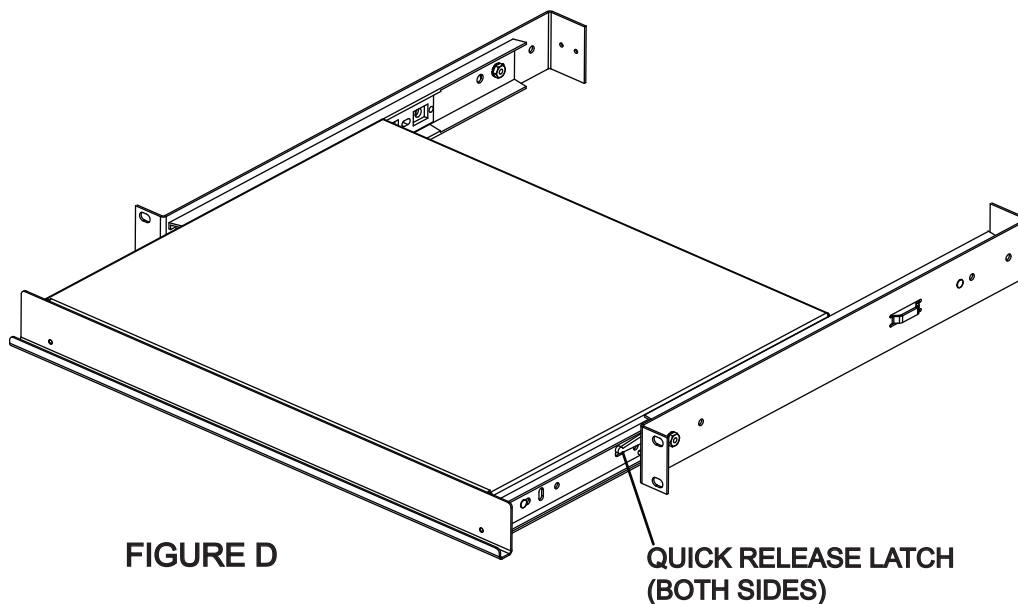

WARRANTY

Middle Atlantic Products, Inc. (the "Company") warrants the UD1 One Rackspace Drawer to be free from defects in material or workmanship under normal use and conditions for a period of (3) three years from date of shipment by the Company.

The Company's entire liability to the purchaser, and the purchaser's (or any other party's) sole and exclusive remedy, under this warranty shall be limited, at the Company's option, to either (a) return of and refund of the price paid for, or (b) repair or replacement at the Company's factory of the products purchased, or any part or parts thereof, which the Company has determined to be defective after defective after inspection thereof at the Company's factory.

This warranty does not cover damage due to acts of God, accident, misuse, abuse or negligence by parties other than the Company, or any modification or alteration of the products. In addition, this warranty does not cover damage due to improper handling, assembly, installation or maintenance.

THIS WARRANTY IS IN LIEU OF ALL OTHER WARRANTIES OF ANY KIND, EITHER EXPRESSED OR IMPLIED, INCLUDING, BUT NOT LIMITED TO, IMPLIED WARRANTIES OF MERCHANTABILITY AND FITNESS FOR A PARTICULAR PURPOSE.

TO THE MAXIMUM EXTENT PERMITTED BY APPLICABLE LAW, IN NO EVENT SHALL THE COMPANY BE LIABLE FOR ANY SPECIAL, INCIDENTAL, INDIRECT, OR CONSEQUENTIAL DAMAGES WHATSOEVER (INCLUDING, WITHOUT LIMITATION, DAMAGES FOR LOSS OF BUSINESS PROFITS, BUSINESS INTERRUPTION OR ANY OTHER PECUNIARY LOSS) ARISING OUT OF THE USE OF THE PRODUCTS PURCHASED, EVEN IF THE COMPANY HAS BEEN ADVISED OF THE POSSIBILITY OF SUCH DAMAGES. THE COMPANY'S LIABILITY TO THE PURCHASER (OR ANY OTHER PARTY) HEREUNDER, IF ANY, SHALL IN NO EVENT EXCEED THE PURCHASE PRICE OF THE PRODUCTS PAID TO THE COMPANY.

Corporate Headquarters

Corporate Voice 973-839-1011 - Fax 973-839-1976
International Voice +1 973-839-8821 - Fax +1 973-839-4982
middleatlantic.com - info@middleatlantic.com

Middle Atlantic Canada

Voice 613-836-2501 - Fax 613-836-2690
middleatlantic.ca - contactcanada@middleatlantic.com

Factory Distribution

USA: NJ - CA - IL Canada: ON - BC

At Middle Atlantic Products we are always listening. Your comments are welcome.

Middle Atlantic Products is an ISO 9001 Registered Company.



30% Recycled Paper

